JCM World Bill Acceptor Calibration

Machines equipped with the World Bill Acceptor (WBA) may be calibrated either at the machine or at a test bench using the WBA calibration kit (p/n 917-453-00). IGT recommends calibration approximately every six months or whenever a problem with bill acceptance is noticed.

Note: *On WBA units with software versions earlier than 1.14, automatic calibration is not possible. For these machines an alternative procedure using a personal computer is necessary. These units may however, be updated to the later software version to allow the automatic calibration. Both procedures are covered in this document.*

The calibration kit includes the following components:

- **Combined Black and White Test Paper (p/n 549-047-90)** – This paper is different than the ones used for previous bill acceptors. It combines both black and white paper in one piece and is automatically fed through the sensor head by the transport mechanism (see Figure 1-1).
- **Adjustment Harness (p/n 600-277-90)** – This harness is used to calibrate the WBA at the machine.
- **Power Supply/Adapter Harness Assembly (p/n 408-089-90)** – This assembly includes a power supply with power cord allowing calibration of the WBA sensor assembly at a location remote from the machine such as a test bench.

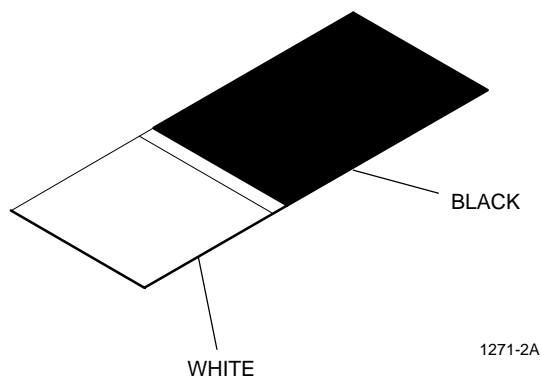

Figure 1-1. WBA Test Paper.



For personal computer calibration the same power supply is used as for the automatic calibration, but different test papers and a magnetic calibration tool are also needed.

The information in this procedure is organized as follows:

- **Automatic Calibration** – describes the process necessary to calibrate units with later software versions either in the machine or at a remote location.
- **Personal Computer (PC) Calibration** – describes this process of calibration on any unit using a PC with the JCM calibration software and appropriate test papers and sensors (required on units equipped with software versions prior to 1.14).

Automatic Calibration

Calibration consists of two procedures, optical sensor calibration and magnetic sensor code programming. The procedures are the same whether for calibration at the machine or remote calibration.

Optical Sensor Calibration

1. Open the machine door and remove the WBA transport and sensor assembly.
2. Set DIP switches 1, 2, 3, and 4 to **off** and 5, 6, 7, and 8 to **on** (see Figure 1-2).
3. Connect the adjustment harness or power supply/adapter harness.

Calibration at the Machine – Connect the adjustment harness between the connector on the WBA chassis and the connector on the transport assembly (see Figure 1-3).

Remote Calibration – Connect the power supply line cord to AC power and the matching connector to the WBA transport assembly.

The WBA performs its normal start-up routine after power is applied. Wait a few seconds until the motors stop.

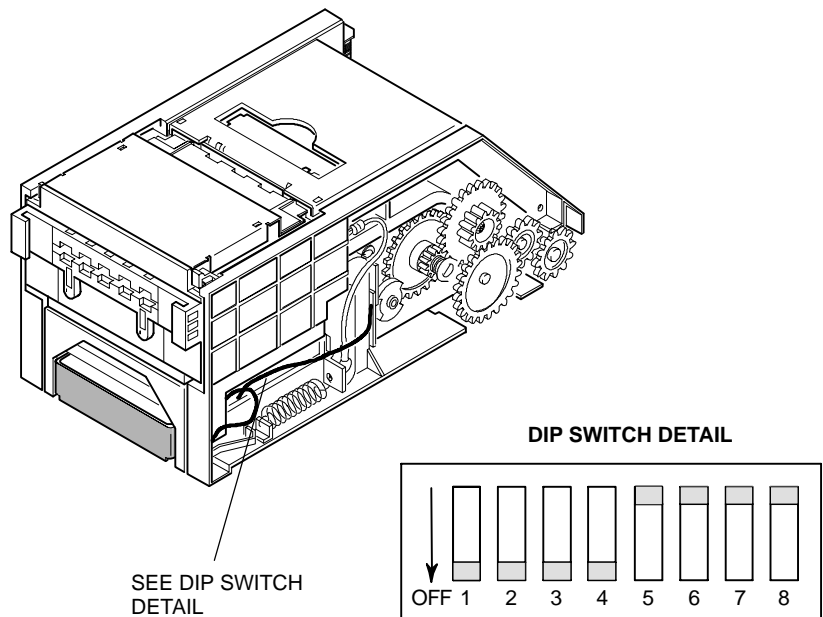

1271-1A

Figure 1-2. Bill Acceptor DIP Switch Settings.

4. Insert the test paper into the sensor assembly, black end first (see Figure 1-4).

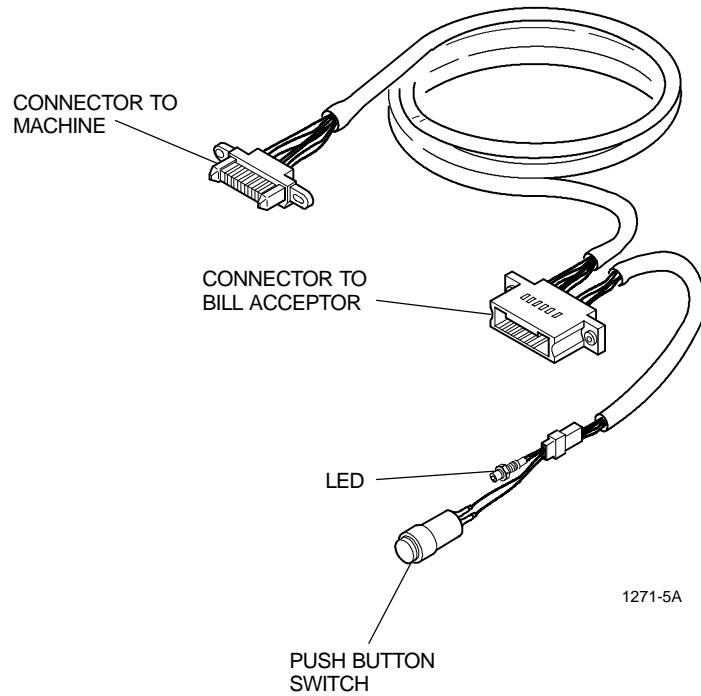

Figure 1-3. Adjustment Harness.

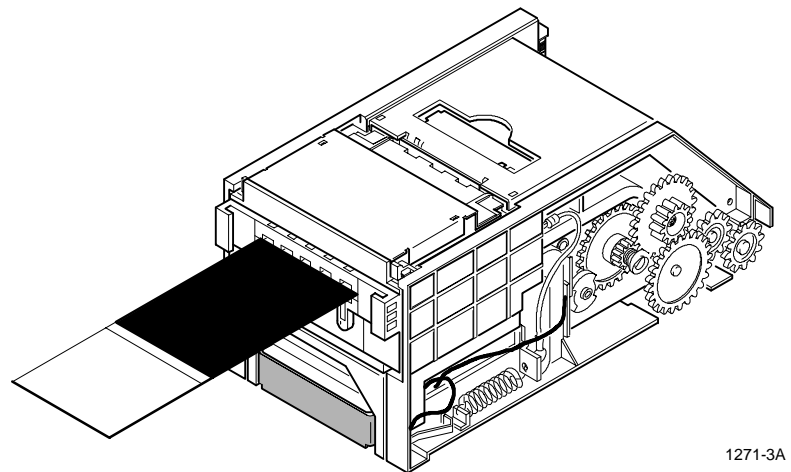

Figure 1-4. Bill Acceptor Test Paper Insertion.

5. The WBA now automatically calibrates the optical sensors, moving the test paper in and out several times as it sets black and white levels and verifies position sensor operation.
6. As the test paper is ejected from the WBA, observe the LED indicator on the adjustment harness (see Figure 1-3). If the calibration was successful, the LED flashes rapidly at about 0.1 second intervals. If there was a problem during the calibration, the LED flashes at a much slower rate (about once a second) a certain number of times to indicate the error condition that caused the problem. Refer to Table 1-1 to determine the error condition.
7. If an error occurs, repeat the calibration procedure. If the error condition persists, replace the sensor assembly. If the error condition still persists, replace the transport assembly.

Table 1-1 WBA Error Codes	
No. of Flashes	Error Condition
1	Entrance level error
2	Solenoid error
3	Entrance – sensor error
4	Transport jam
5	Gain error (white level adjustment error)
6	D/A error (white level adjustment error)
7	Bar code sensor error
8	Acceptor head remove
9	Magnetic sensor code error
10	Write error
11	Black level adjustment error

Magnetic Sensor Calibration

On U.S. bill acceptors a magnetic sensor is used in conjunction with the optical sensors to verify valid currency. This magnetic sensor requires calibration only when either of the printed circuit boards in the sensor assembly is replaced.

The magnetic sensor is calibrated by recording the printed code letter (see Figure 1-5) from the sensor into bill acceptor memory. To calibrate the magnetic sensor use the following procedure.

1. Record the code letter from the magnetic sensor (see Figure 1-5).

Note: On later units this code letter is recorded on a label attached to the outside of the sensor assembly. On early units without labels, record the code letter on the outside of the sensor assembly to avoid having to disassemble the sensor assembly.

To remove the board for access to the sensor:

- a. Remove the sensor assembly from the transport.
- b. Slide the sheet metal cover off the sensor assembly toward the rear of the assembly.
- c. Remove the electrical connector from the board.
- d. Remove the three screws and the board from the sensor assembly.
- e. Assembly is the reverse of the above procedure.

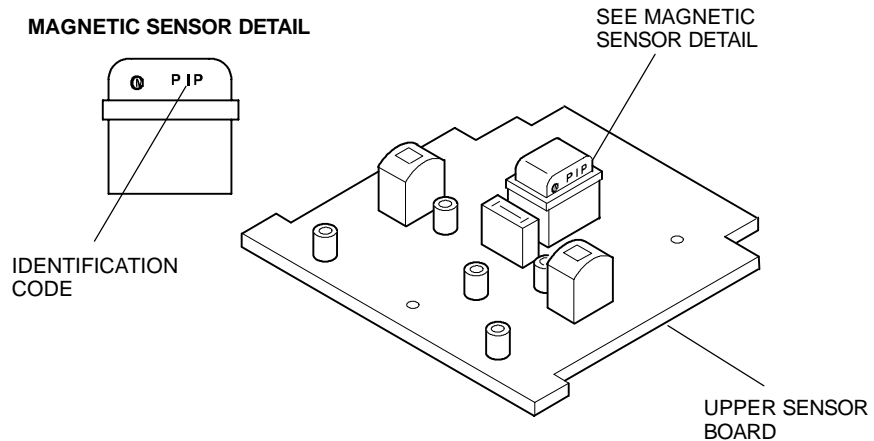

1271-4A

Figure 1-5. Magnetic Sensor.

2. Set DIP switches 1, 2 and 3 to **off** and 4, 5, 6, 7 and 8 to **on** (see Figure 1-2).

3. Connect the adjustment harness or power supply/adapter harness.

Calibration at the Machine – Connect the adjustment harness between the connector on the WBA chassis and the connector on the transport assembly (see Figure 1-3).

Remote Calibration – Connect the power supply line cord to AC power and the matching connector to the WBA transport assembly.

4. The LED on the adjustment harness should be flashing at about one second intervals.

5. Set all of the DIP switches to the **off** position.

6. Using Table 1-2, turn on the DIP switch corresponding to the magnetic sensor code letter noted in step 1.

7. Press the adjustment harness push-button once to enter the magnetic sensor code.

8. Observe the LED indicator on the adjustment harness (see Figure 1-3). If the calibration was successful, the LED flashes rapidly at about 0.1 second intervals. If there was a problem during the calibration, the LED flashes at a much slower rate (about once a second). The LED flashes nine times to indicate a magnetic sensor error.

9. If an error occurs, repeat the calibration procedure. If the error condition persists, replace the sensor assembly. If the error condition still persists, replace the transport assembly.

Table 1-2 WBA Magnetic Sensor Programming Settings	
Code Letter of Magnetic Sensor	DIP Switch to Turn On
F	4
G	3
H	3
I	3
J	2

Personal Computer Calibration

PC calibration is necessary on units with bill acceptor software versions before 1.14, and optional on any unit. In order to perform these procedures the following additional equipment is necessary.

- **Separate Black and White Test Paper Assemblies with Locator Brackets (p/n 549-049-90 and 549-050-90)** – are needed for the PC procedure because the WBA does not cycle the paper in and out as it does using the automatic procedure.
- **Magnetic Calibration Tool (p/n 549-048-90)** – is used to calibrate the center magnetic sensor instead of the programming method used in conjunction with the automatic procedure.
- **Calibration Software** – is necessary to perform the procedure and is available through IGT Customer Service at (702) 448-0364.
- **IBM PC AT or Compatible PC** – with a serial port and MS-DOS version 6.0 or later.

Note: *These items must be ordered separately; they are not part of the automatic calibration kit 917-453-00.*

Connecting the PC and Starting the Calibration Software

1. Connect the power supply/adaptor harness to the bill acceptor transport connector, the serial 9-pin connector to the serial port on the PC and the power cord to an AC power source.
2. Turn on power to the PC and start MS-DOS.

Note: *The calibration software requires MS-DOS version 6.0 or later to operate. The calibration software will only run directly in DOS, not in a Windows DOS window.*

3. Insert the calibration software disk into the floppy disk drive and change to that drive.
4. Type “adj10” and press the **[ENTER]** key.
5. The software identification screen appears. Press the **[ENTER]** key to continue.

Note: The calibration software may also be loaded onto the PC's hard drive. A separate directory must be created for the calibration software. To operate from the hard drive, change to the directory where the software is located and follow the procedure from step 4 above.

Optical Sensor Calibration

The optical sensors are calibrated by following the commands displayed on the PC screen after the calibration software is activated.

1. After starting the software, the first screen message appears on the PC screen.
"Set White reference paper. Hit enter key."
2. Open the sensor assembly cover and install the white test paper (p/n 549-050-90) into the sensor assembly as shown in Figure 1-6.
3. Close the sensor assembly cover and press the **[ENTER]** key on the PC. Do not move the sensor assembly or test paper during the adjustment.
4. The message "Adjusting" appears on the PC screen.
5. After this adjustment is complete the screen message, appears on the PC screen.
"Set Black reference paper. Hit enter key."
6. Open the sensor assembly cover, remove the white test paper, and install the black test paper (p/n 549-049-90) into the sensor assembly as shown in Figure 1-6.
7. Close the sensor assembly cover and press the **[ENTER]** key on the PC. Do not move the sensor assembly or test paper during the adjustment.
8. Follow the on-screen instructions inserting either the black or white test paper or no test paper into the sensor assembly and pressing the **[ENTER]** key after each paper change.
9. When the optical sensors are calibrated, this message appears on the PC screen.
"Set Mag Head Tester. Hit enter key."
10. Proceed to the next section, Magnetic Sensor Calibration.

TEST PAPER ASSEMBLY WITH
LOCATOR BRACKET

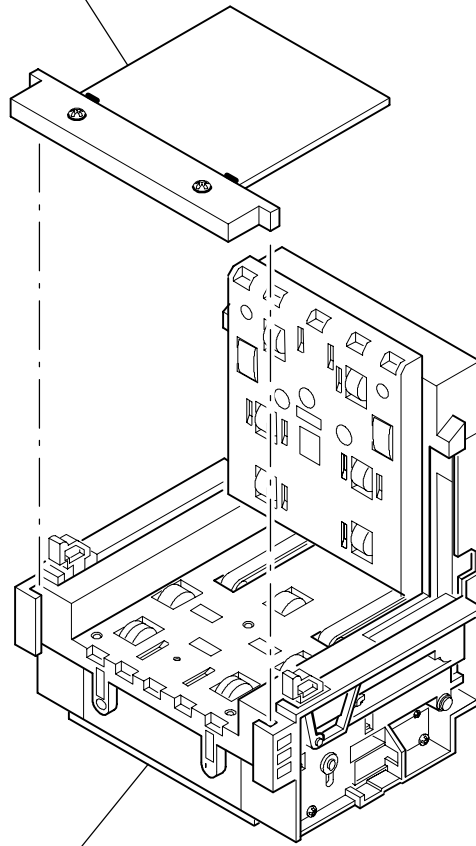

SENSOR ASSEMBLY

1271-6A

Figure 1-6. Test Paper Insertion – PC Calibration Procedure.

Magnetic Sensor Calibration

The magnetic sensor calibration tool is a separate unit with its own AC power source. It has no direct connection to the PC, it provides a magnetic field to the magnetic sensor when it is inserted in the WBA sensor assembly.

1. Connect the AC power cord on the magnetic sensor calibration tool to a power source.
2. Install the magnetic sensor guide in the front of the sensor assembly in the same way the test papers were installed in step 2 of the Optical Sensor Calibration procedure.

3. Insert the magnetic calibration board into the front of the guide so that the end of the board is to the rear of the sensor assembly.
4. Close the sensor assembly cover and press the **[ENTER]** key on the PC.
5. The “Mag Gain Adjust” screen appears on the PC.
6. Move the magnetic calibration board in and out until the value indicated on the scale reaches its peak.
7. Press the **[ENTER]** key on the PC.
8. The message “Adjusting Mag Gain” appears on the PC screen.
9. After this automatic adjustment is complete, this message appears on the PC screen.
“Write the Adjustments to Vali Head. Yes->Y No->N :”
10. Type “Y” to write the calibration values into the WBA sensor assembly memory. Typing “N” at this time would retain the previous calibration values in the WBA sensor assembly memory.
11. The calibration is now complete. Press **[ENTER]** to calibrate another sensor assembly or press **[ESC]** to exit the program.